

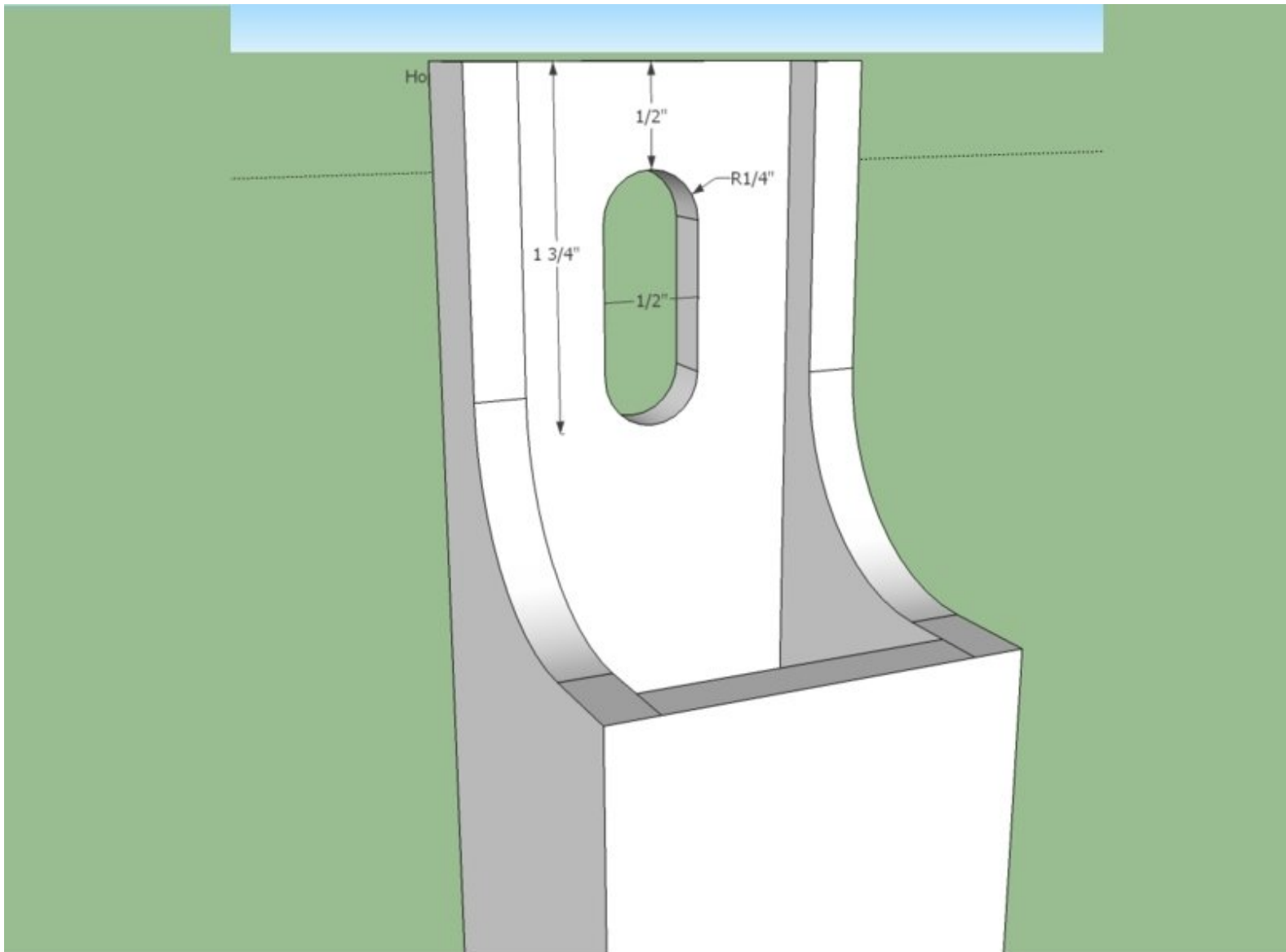

CEB Hopper Supports and Grate Supports

Written By: Dozuki System



INTRODUCTION

- [Hopper Support Model](#)* [Grate Support Model](#)Additional Materials Required:* 3/4"x1.5" Bolts (2)* 3/4" Nuts (2)* [invalid guide link]

TOOLS:

- [Angle grinder](#) (1)
 - [Punch](#) (1)
 - [torch](#) (1)
 - [Welder](#) (1)
-

Step 1 — Make the Hopper Supports

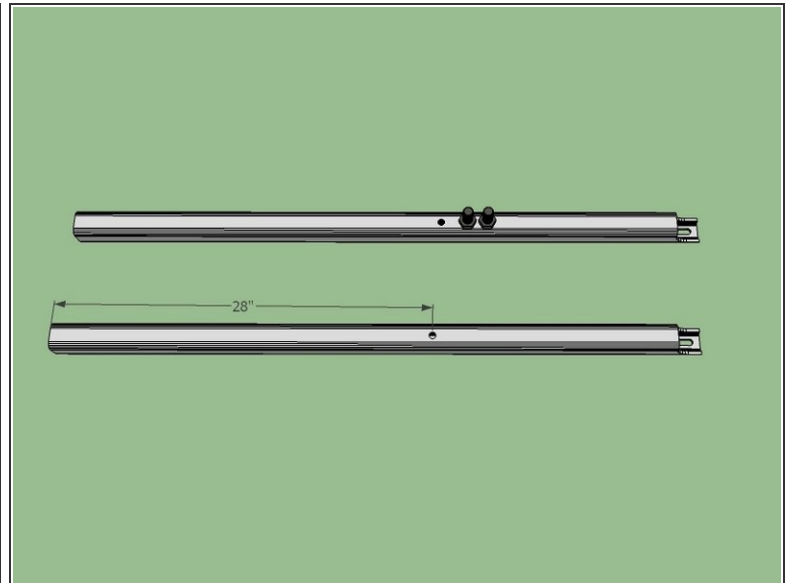
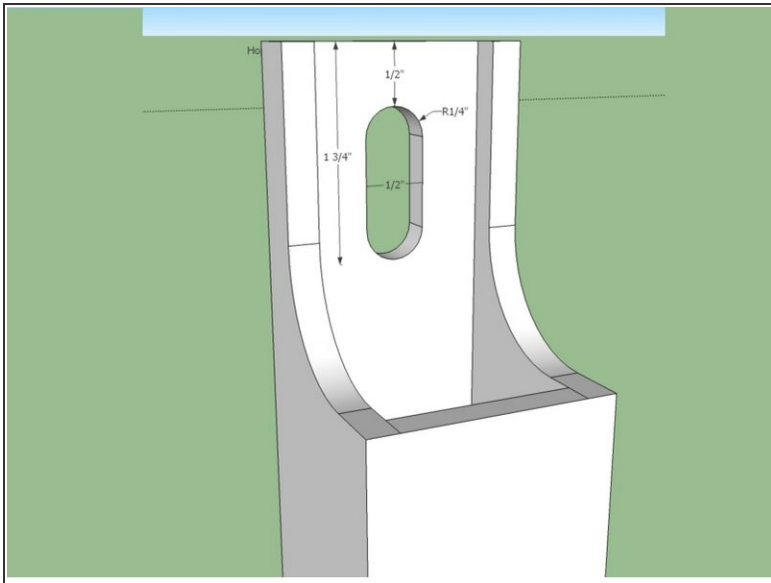

- Torch away the necessary areas. See diagrams.
- The holes for the hopper mounting need to be 28" away from the bottom side. Mark 28" on the opposite tubing walls and torch 1/2" holes. Insure a 1/2" bolt goes all the way thru.
- Torch the cutaway at the top and the slot.
- Grind away any slag.

Step 2



- Lay one support on the table, with the grate mount slot touching the table.
- Get the Shaker Mount and tighten 3/4" bolts with nuts to the Soil Shaker so the bolt head is where the hammer will be.
- Prop this up on the hopper support, so the first bolt is about 2" above the 28" hole and both bolts are touching the support.
- Mark which side of the shaker you are welding the bolts for.

Step 3

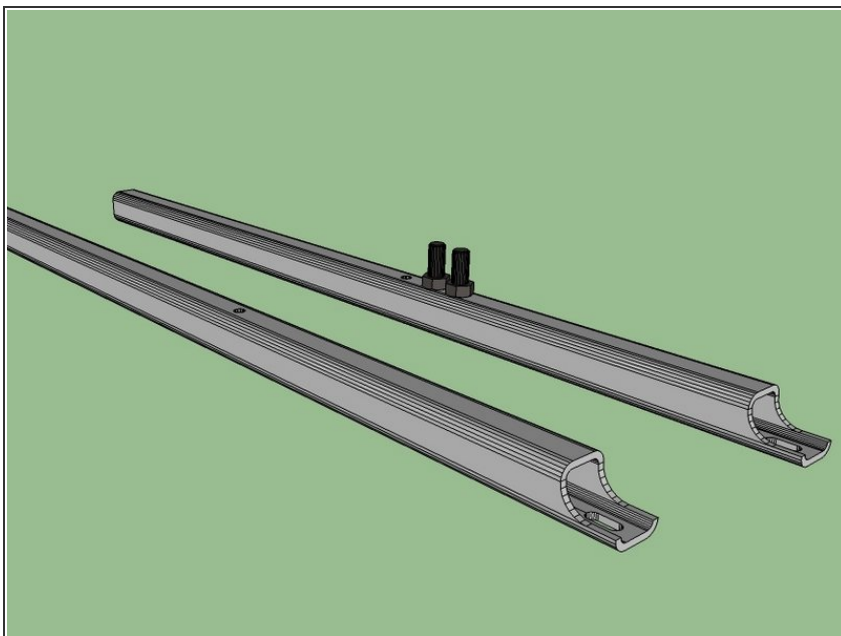

- Tack the bolts in place, remove the nuts and dismount the shaker.
- Protect the threads, and finish welding the bolts to the support.
- ⓘ You are only doing this on one of the supports, the other side, you will do in place, so the spacing is correct.

Step 4 — Make the Grate Supports.

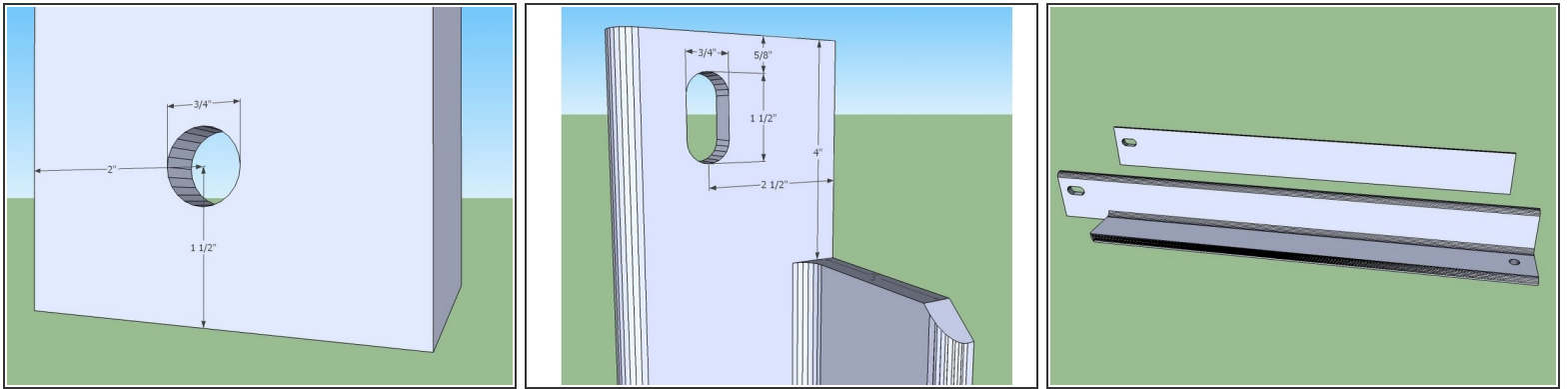

- Punch the hole on the bottom of the supports for each.
- Torch away a 4" section on the top of each grate to make it like the model shown.
 - Remember that the two are mirrored.
 - Cut away the corner so the hopper won't hit it, about a 1" 45 degree triangle.
 - Torch a slot for a 3/4" bolt at the top of the mount, as shown.
- Grind away all the slag.