

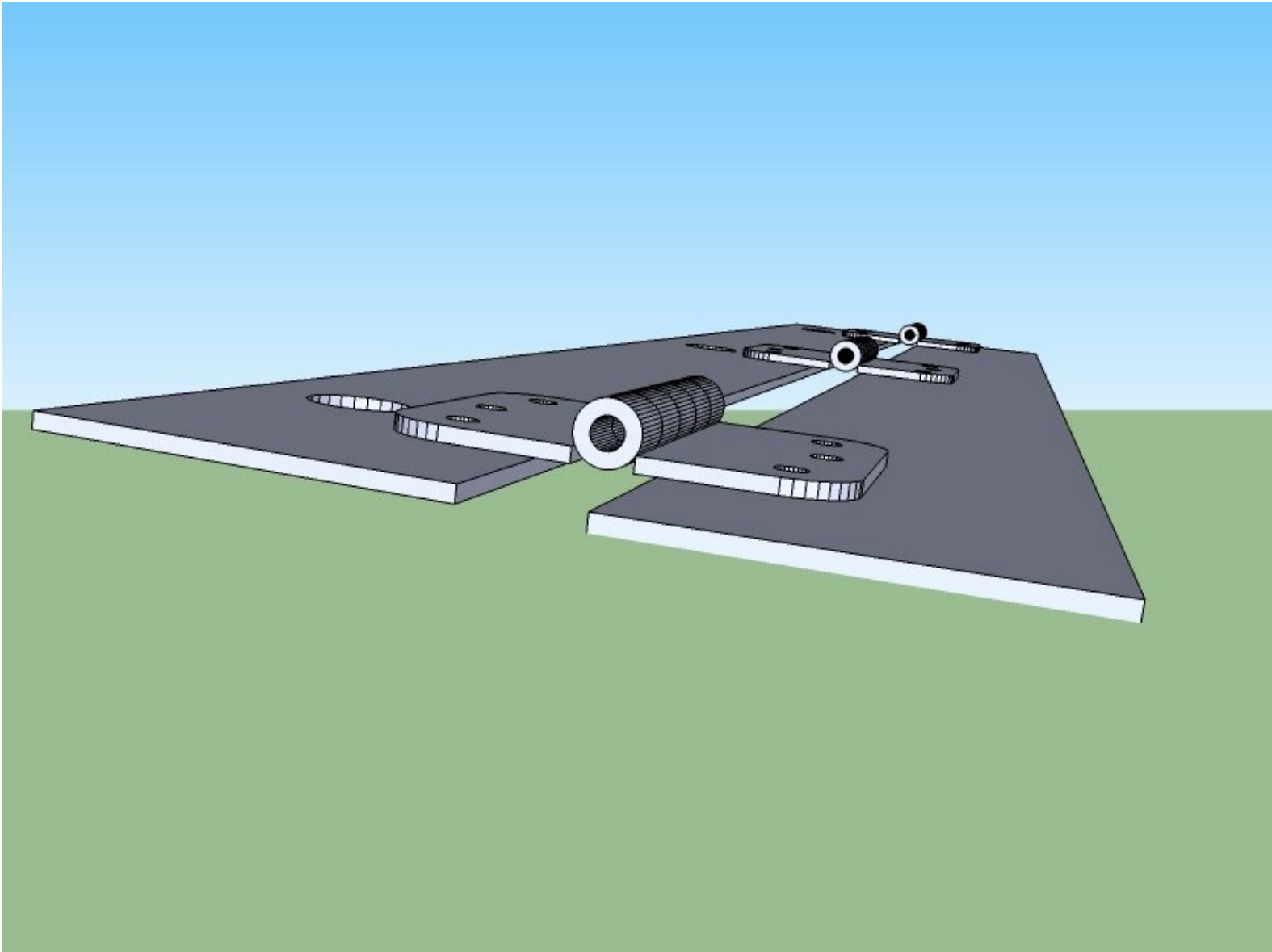

Prepare the Hopper Sheet Metal

Written By: Dozuki System



INTRODUCTION

[Sketchup Model](#) Additional Materials Required: * Hinges (12) * 1/2"x1" Bolts (12) * 1/2" Nuts (12) * 1/2" Washers (12)

TOOLS:

- [Angle grinder](#) (1)
 - [hole puncher](#) (1)
 - [torch](#) (1)
 - [Welder](#) (1)
 - [Wrenches or sockets](#) (1)
-

Step 1 — Prepare the hinge plates



- Punch holes in 4 of the hinge plates as shown with a 7/8" or 1" punch.
- Weld one plate with holes, one without holes, and 3 hinges together as shown, with the plates 1 1/8" apart and the hinge centered.
- Make sure the side of the hinge that sticks out most is on the top; this way it won't interfere with the hopper metal below when installing the hopper.
- Make 3 more of these.

Step 2 — Attaching the hinge plates to the hopper metal

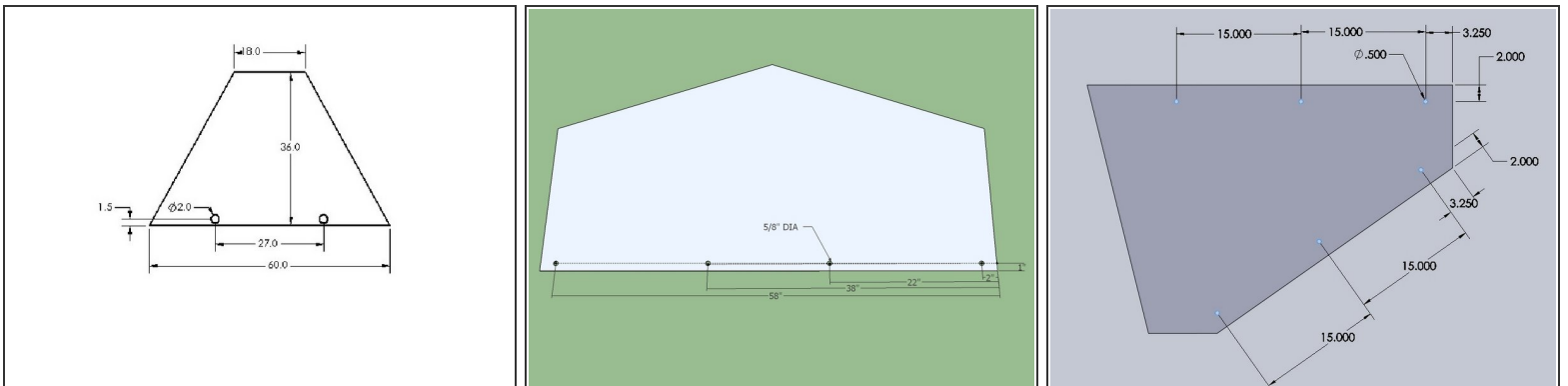

- Torch the holes shown in the front piece.
- Punch all of the holes shown in the side pieces and dirt deflector plate.

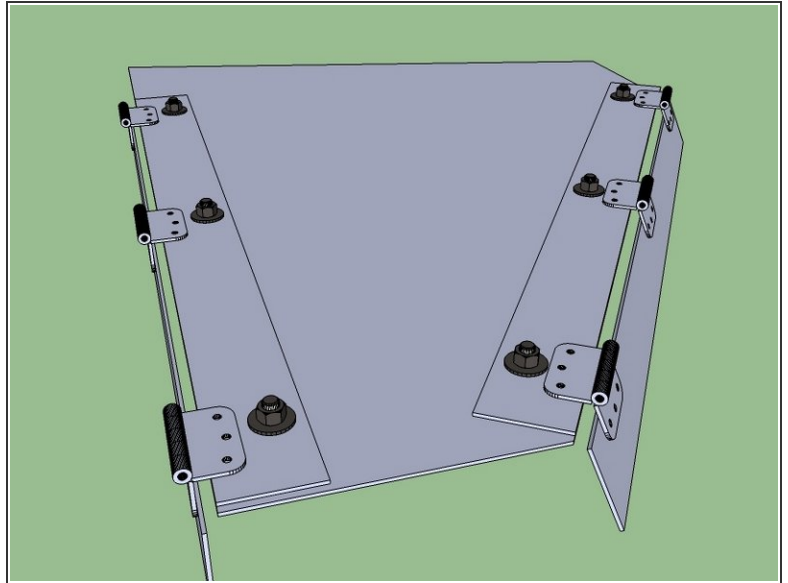
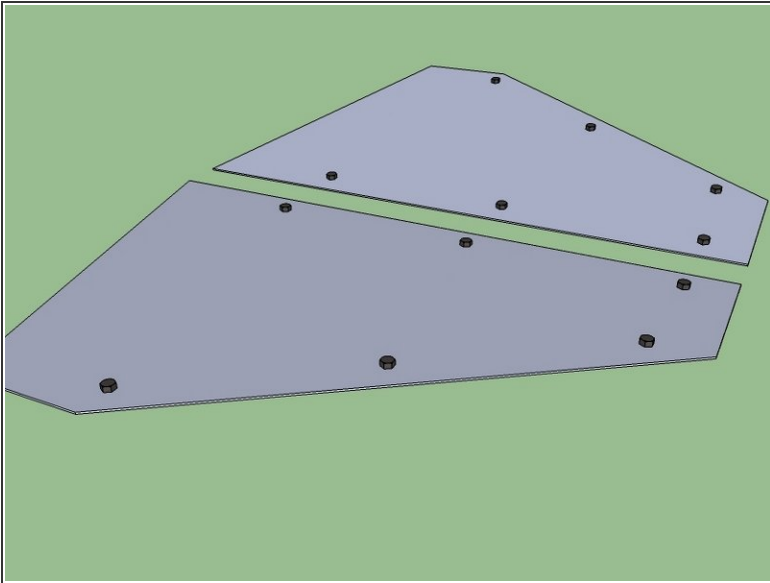
Step 3

- Place 1/2" bolts thru the side pieces and weld them.
 - Make sure you are making them mirror images of each other.
- Bolt the hinge plate assemblies to the side pieces using a washer, lock washer, and nut on each bolt