

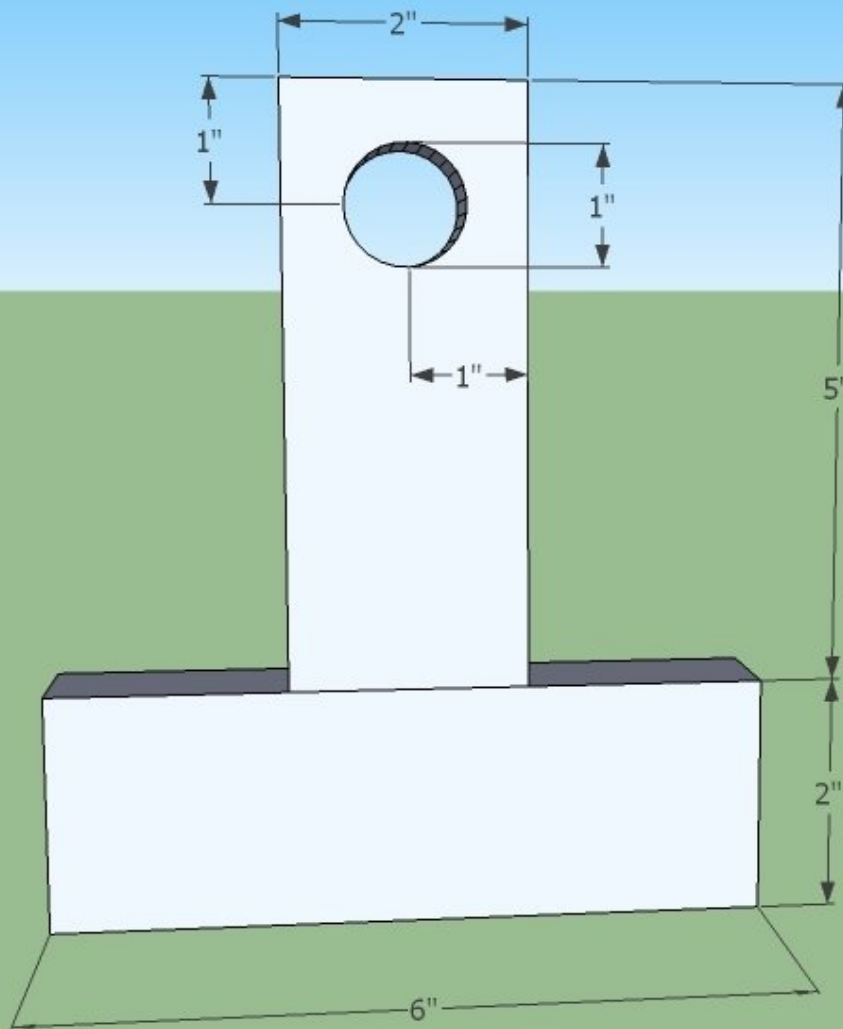

# CEB Shaker Hammer and Shaft

Written By: Dozuki System



---

## INTRODUCTION

[Sketchup Model](#) Additional Materials Required: \* 1" Keyed Coupler\* 1/4"x 2" Bolt

---



### PARTS:

- [Welder](#) (1)
  - [Angle grinder](#) (1)
  - [Drill press](#) (1)
  - [Chalk or something to mark steel with](#) (1)
-

## Step 1 — Prepare the hammer

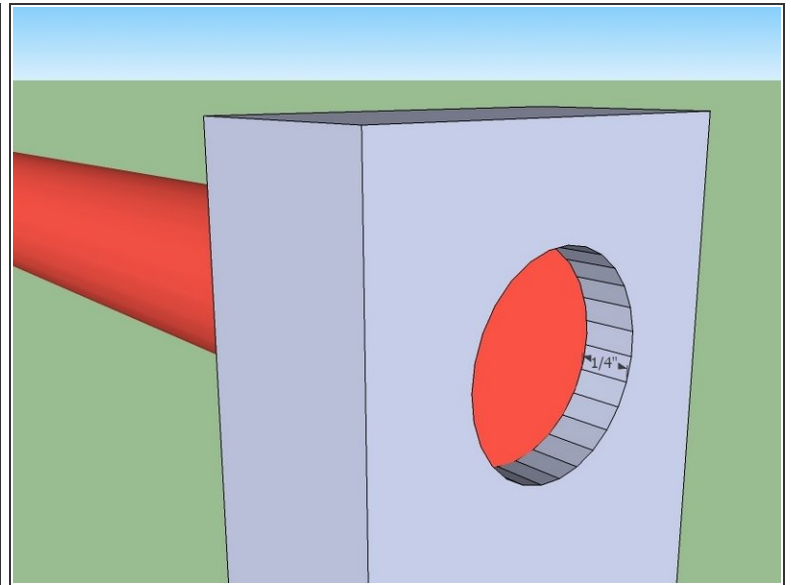
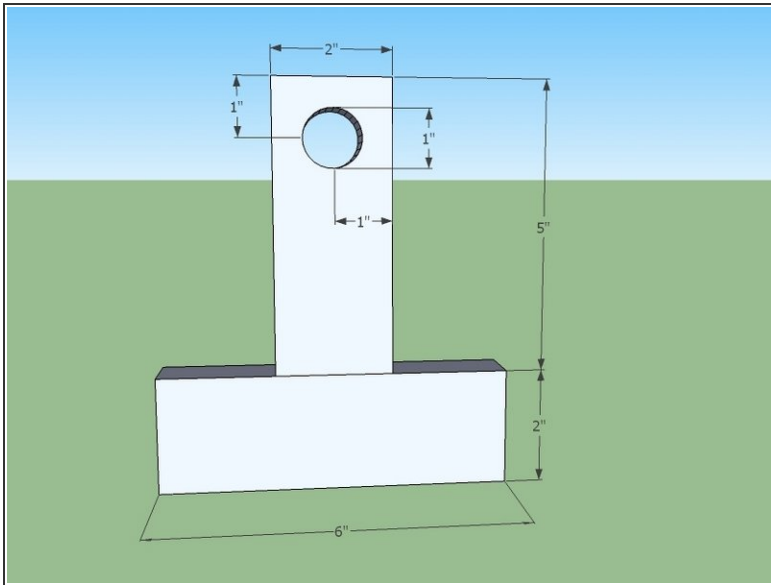

- Drill or punch the hole in the flatbar.
- Weld the two pieces of flatbar together.
  - ⚠ This needs to be a really strong weld! The hammer will be under a lot of stress, and if it's not a solid weld, it could fly off! (This is why the guard is there.)
- Tack the shaft into the hole so there's about a 1/4" distance between the end of the shaft and the opposite side of the hammer.

## Step 2 — Couple the shaft

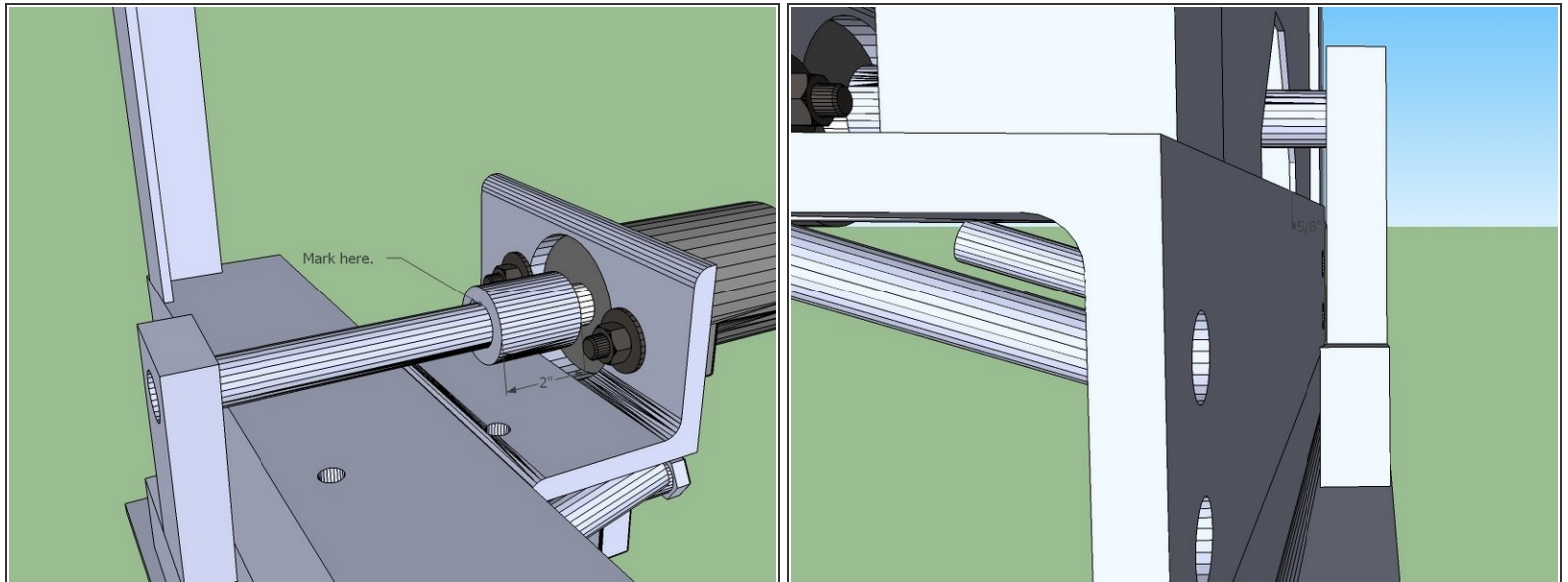

- Cut the coupler down so it's 2" long. It doesn't matter from which side you cut it.
- Get the shaker motor, the mount you made, the shaft/hammer, and the coupler.
- Put the shaker motor onto the mount and couple the shaft to it. Mark where the shaft enters the coupler.
  - Make sure the coupler won't be rubbing on the mount while it spins.
- Make sure the hammer has about 5/8" clearance from the mount.
  - If not, you can pull it out of the coupler a little, but make sure the bolt won't be too close to the edge.
  - Otherwise, you can grind away the tacks on the hammer and tack it properly.

### Step 3 — Drill hole for bolt in coupler

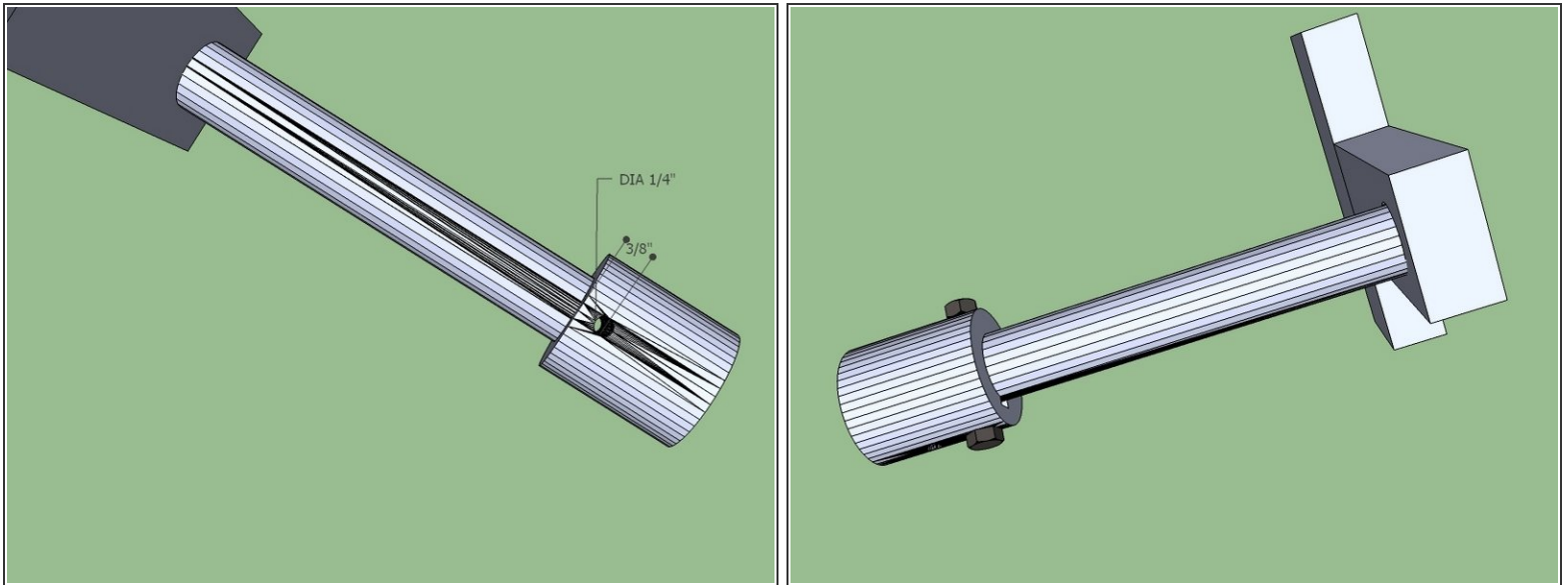

- Remove the motor and shaft from the mount.
- Put the coupler back onto the shaft.
- Drill the 1/4" hole thru the coupler and rod, using the mark you made to make sure the rod is inside the coupler by the proper amount.
  - The hole should be 3/8" away from the edge of the coupler.
  - Drill thru both at the same time. You will need some sort of vise to hold it down while you drill.
- Double-check that your bolt will fit thru. If not, either re-drill it with a slightly bigger bit, or do another set of holes.

## Step 4 — Weld the shaft to the hammer



- Remove the coupler.
  - Fully weld the hammer to the shaft, plug-welding the back side, and welding around the shaft on the other side.
-  Make sure this weld is SOLID.