

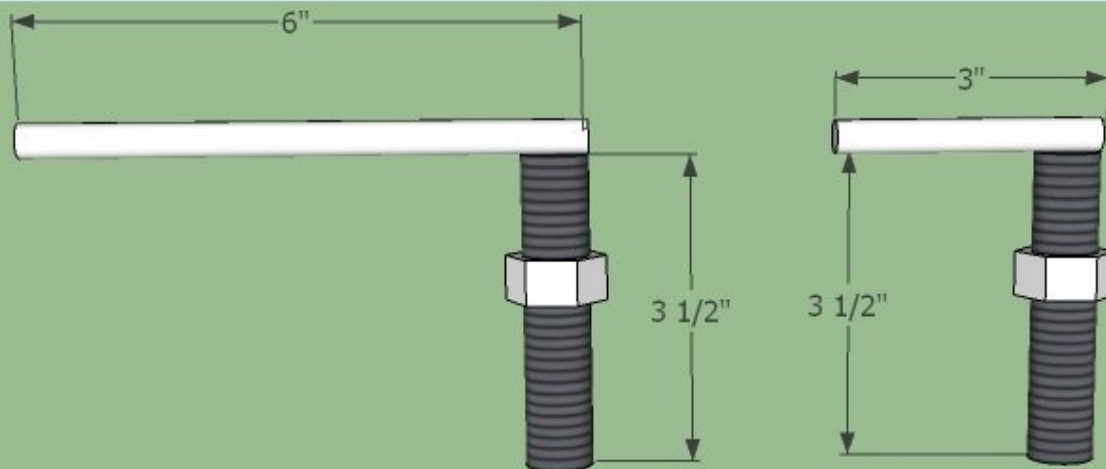

# CEB Main Frame: Small Components

Add small components to your Compressed Earth Brick Press.

Written By: Dozuki System



---

## INTRODUCTION

[Sketchup Model](#) Additional Materials Required: \* 3/4" Galvanized Nuts (3) \* 3/4" Steel Nuts (2)

---

### TOOLS:

- [Welder](#) (1)
-

## Step 1 — Make the sensor holders

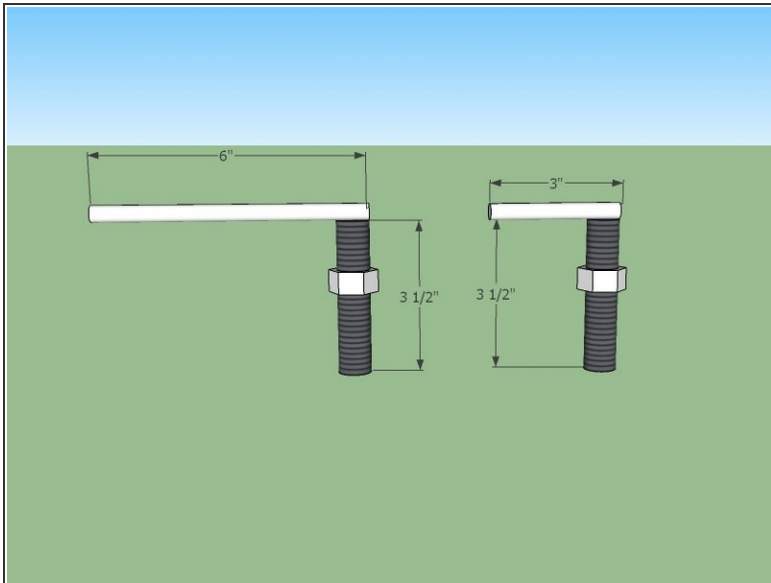

- One is for the main frame, and one goes in the primary arms.
- Weld the rebar to the threaded rod at a right angle.
  - Protect the threads on the threaded rod by welding. (A small pipe works well)
- Thread a nut onto it.

## Step 2 — Make the Thin Cylinder Supports

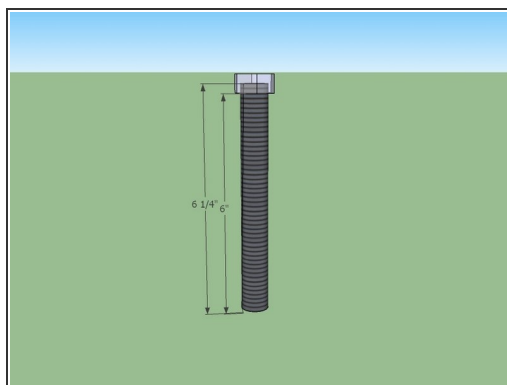
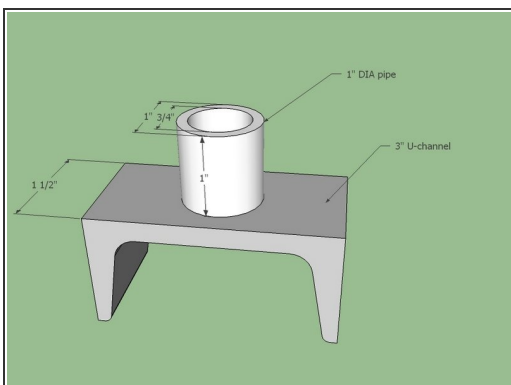

- Weld the 1" pipe to the 3" U-channel, in the center. 4-8 good tacks is sufficient.
- Make (2) 6" long 3/4" bolts, by using a nut and 6.25" of threaded rod. See [Making Bolts](#).

### Step 3 — Make the Magnet Holder

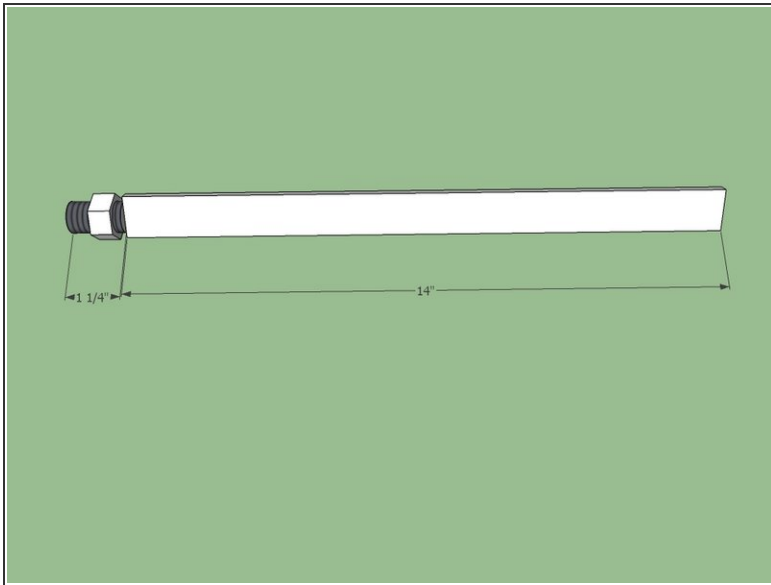

- Weld the flatbar to the 1.25" piece of threaded rod.
  - Protect the threads.
- ⚠ Make sure they are perfectly parallel!
- Thread a nut onto the threaded rod.