

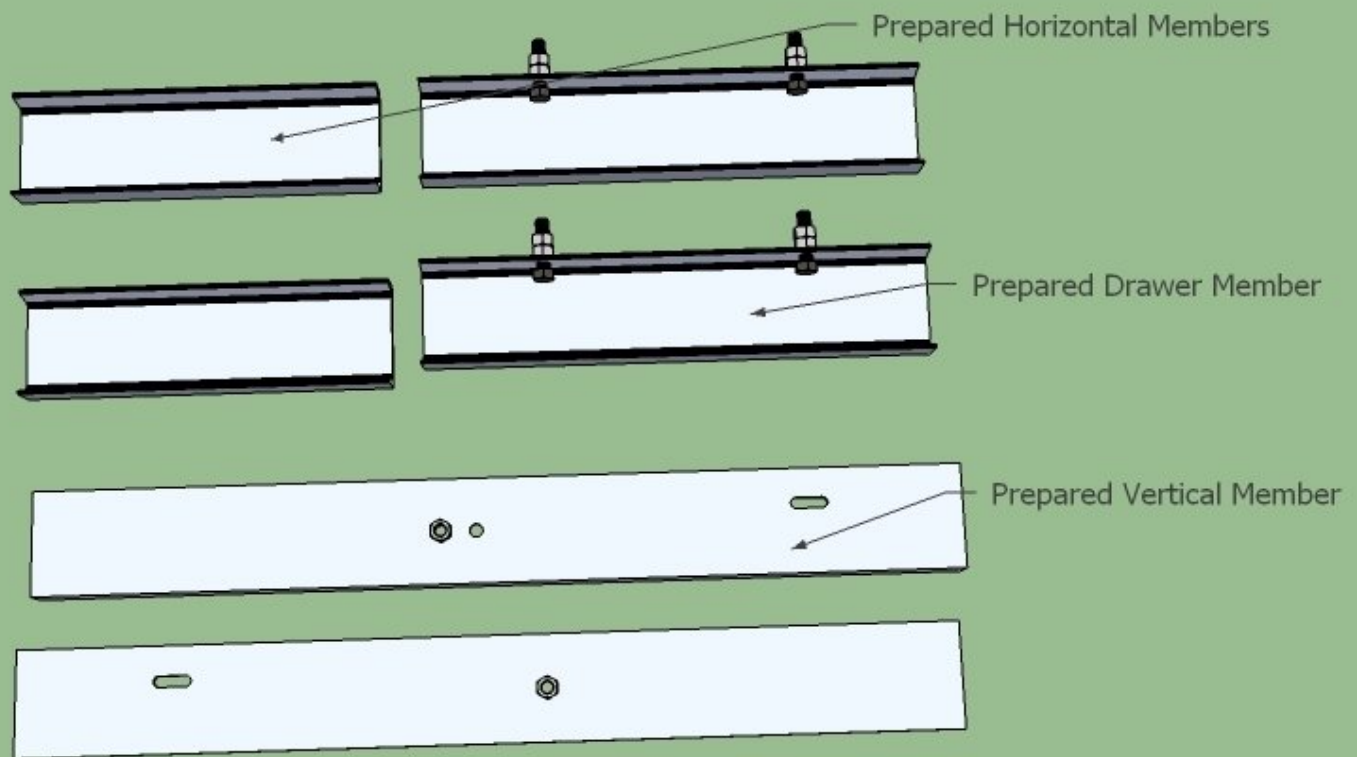

CEB Main Frame: U-Channel Prep

Prep the U-channel for the Compressed Earth Brick Press main frame.

Written By: Dozuki System



INTRODUCTION

[Sketchup Model](#) Additional Materials Required: * 3/4" Galvanized Nuts (4) * 3/4" Steel Nuts (10)

TOOLS:

- [Grinder](#) (1)
 - [hole puncher](#) (1)
 - [torch](#) (1)
 - [Welder](#) (1)
-

Step 1 — Prepare the horizontal members

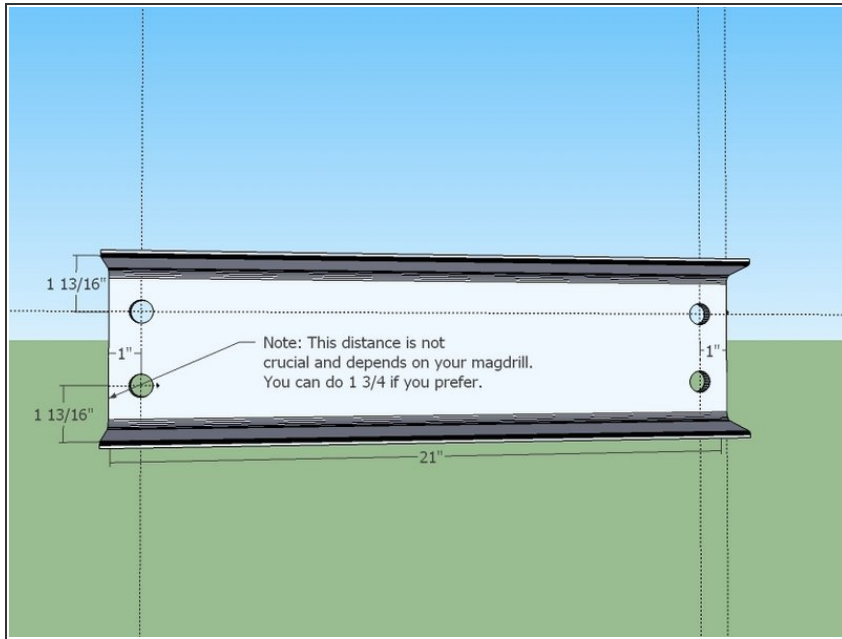

- Mark the holes in the horizontal members as shown in the diagram. Center punch them.
- ⚠ DON'T PUNCH THEM! They will be mag-drilled in a later guide.

Step 2 — Prepare the drawer members.

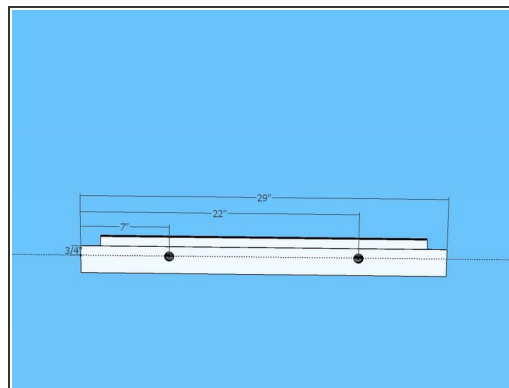
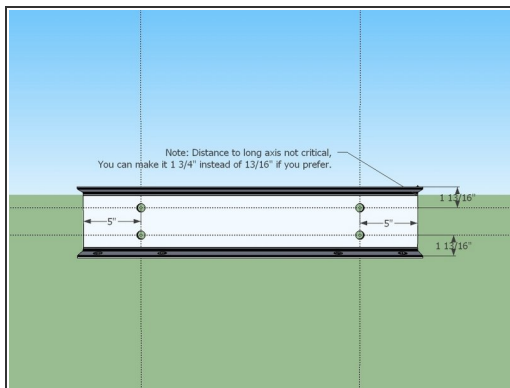

- Mark and center punch the 4 holes on the face of the U-channel.
 - DON'T PUNCH THEM! They will be mag-drilled later
- Torch holes for 3/4" drawer adjustment bolts as shown in the diagram.
- Grind away the slag.

Step 3



- Weld 3/4" nuts to the outside of the U channel where the holes are torched.
- Weld it with a bolt coming thru the other side so it protects the threads and so you know the nut won't get off center.
- Grind away any spatter between the bolts.
- Make (4) 3/4" x 3.5" bolts using 3.75" threaded rod and steel nuts. See [Making Bolts](#).
- Thread the bolts through the nuts and thread another nut on top as shown.

Step 4 — Prepare the vertical members.

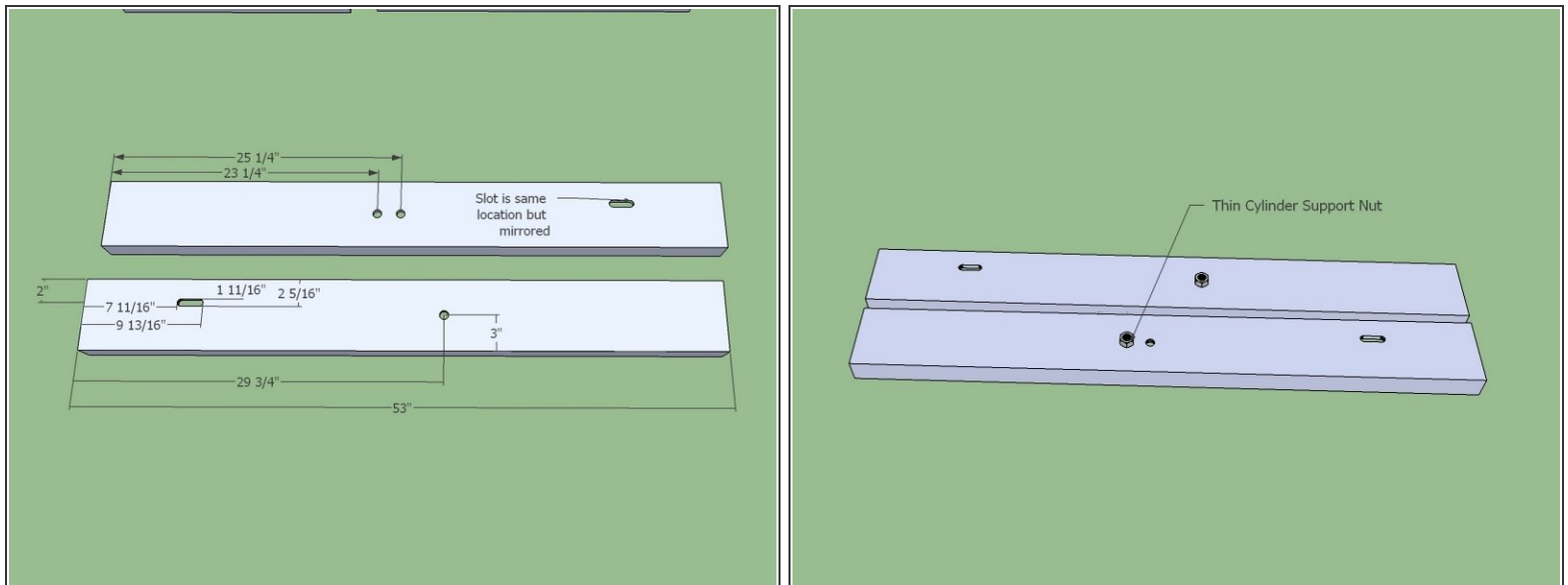

- Punch the holes as shown. The diameters are 3/4".
- Torch the roller slots as shown.
 - Insure a 1/2" bolt goes thru it.
- Grind away the slag.
- Weld the the thin cylinder support nuts, taking care to protect the threads.